

# VALVES

TYPE : TIPPING VALVES

VLV.TYPE

DVT#

Pneumatic proportional tipping valve – Side Port Modular 150 Direct

## Technical Characteristics

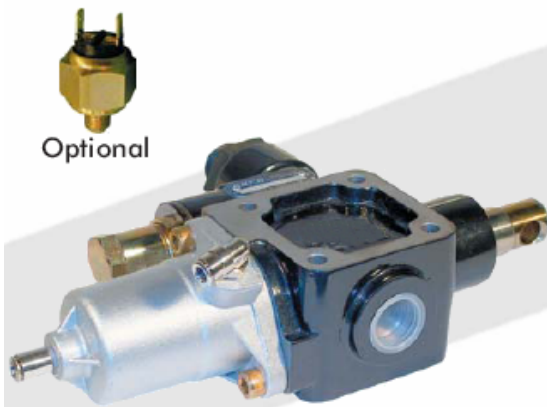

Optional

Valvola ad azionamento pneumatico per il comando di ribaltabili medio-pesanti, con schema idraulico a centro aperto in accordo alle direttive CE. Utilizzabile con il deviatore pneumatico tipo Kip-Air, per ottenere una modulazione continua della velocità di discesa.

- Valvola di ritegno e valvola di massima pressione registrabile (tipo diretto) incorporate.
- Corpo in ghisa sferoidale per sopportare pressioni fino a 400 bar
- Possibilità di montaggio a telaio oppure flangiata direttamente al serbatoio (DSP).
- Fine-corsa meccanico ad azionamento diretto.
- Predisposizione per segnalatore di pressione.
- Corpo verniciato in cataforesi e cursore nichelato.- Garantito per lavorare con olio a temperature  $-25 \div 80$  °C, campo di viscosità  $12 \div 100$  cSt e grado di filtrazione  $25 \mu\text{m}$ .

Proportional pneumatic tipping valve to suit medium-heavy duty tipper trucks. Operated by proportional cab control. Open center hydraulic scheme according to CE standards.

- Built-in check and adjustable safety valves (direct type).
- Nodular cast-iron body for pressure up to 400 bar.
- Either Chassis or tank (DSP kit) mounting options.
- Mechanical Direct End-of-stroke with anti-shock spring.
- Ready for pressure signal switch mounting.
- Cataphoresis coated body and nickel spool.
- Guaranteed for oil temperature range  $-25 \div 80$  °C, viscosity range  $12 \div 100$  cSt and oil filtering  $25 \mu\text{m}$ .

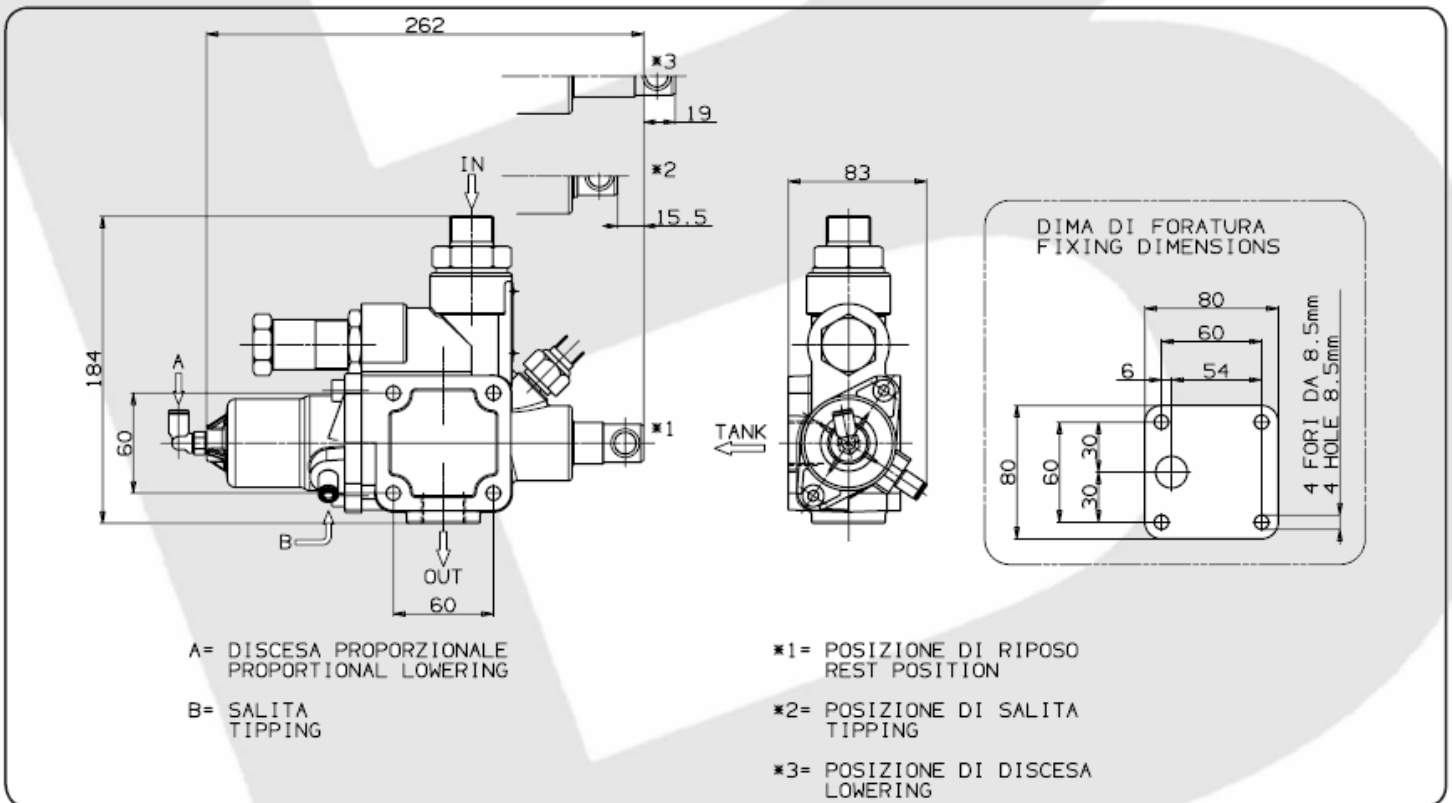

Tipo deviatore Tipping valve type	Codice ordinazione Order code	IN	TANK	OUT	Peso Weight
MODULAR 150 CE	DVT#7	ISO 228 G 3/4	ISO 228 G 3/4	ISO 228 G 3/4	Kg 5,8

## BINOTTO SRL

BINOTTO IS CONTANTLY ENGAGED IN IMPROVING ITS PRODUCTS AND THEREFORE RESERVES THE RIGHT TO MODIFY WITHOUT ANY NOTICE CHARACTERISTICS SHOWN

VIA DIVISIONE JULIA, 7/B - 36031 DUEVILLE [VI] ITALY • TEL. 0039.0444.593290 - FAX. 0039.0444.593357 • E-MAIL. INFO@BINOTTO.COM

Edit.: 04 • 2006  
Rev.: 04 • 2007  
Date: 01.04.2006

Pag.: DVT\_7.001

# VALVES

TYPE : TIPPING VALVES

VLV.TYPE

DVT#

Pneumatic proportional tipping valve – Side Port Modular 150  
Direct

## Technical Characteristics

Tipo deviatore <i>Tipping valve type</i>	Codice ordinazione <i>Order code</i>	Pressioni <i>Pressure values</i>		Portata <i>Flow</i>
		Taratura standard <i>Standard pressure setting</i> bar	Taratura massima <i>Max. pressure setting</i> bar	
<b>MODULAR 150 CE</b>	<b>DVT#7</b>	160	280	150

**Perdite di carico deviatore**  
*Tipping valve pressure drops*

**Curva caratteristica p-Q valvola di massima**  
*p-Q operating curve for pressure relief valves*

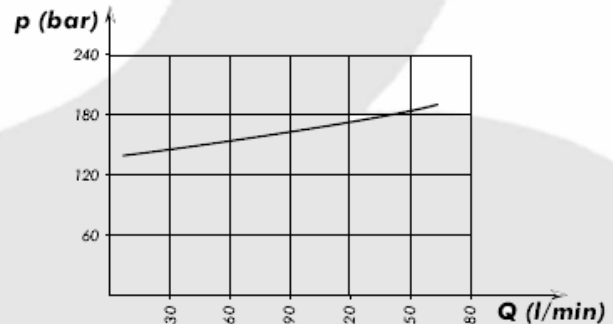
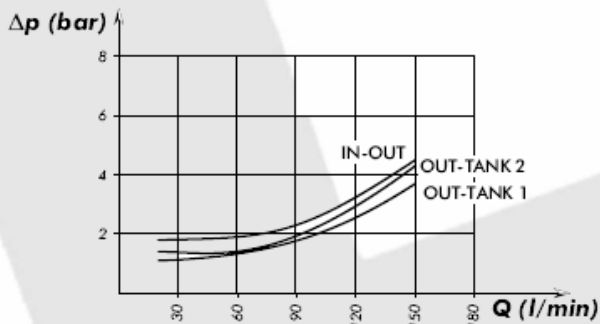

Rilievi eseguiti con olio ISO VG 46 a 50°  
*The graph refers to oil type ISO VG 46 a 50°*

**Schema di funzionamento**  
*Functional diagram*

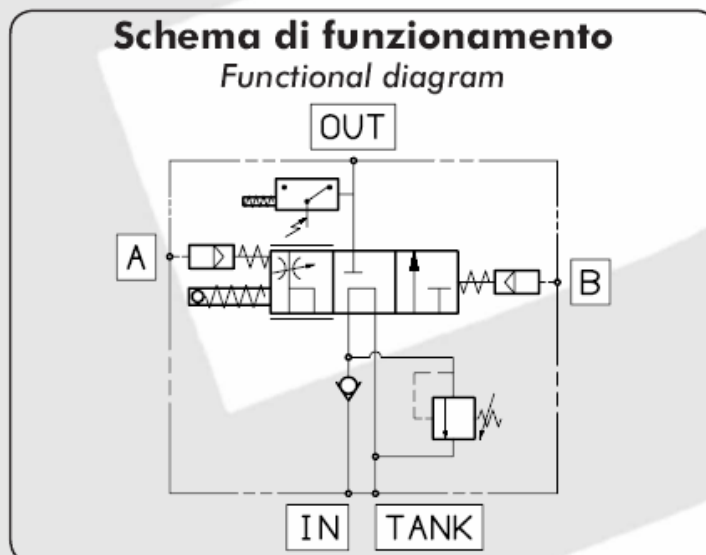

**BINOTTO SRL**

BINOTTO IS CONTANTLY ENGAGED IN IMPROVING ITS PRODUCTS AND THEREFORE RESERVES THE RIGHT TO MODIFY WITHOUT ANY NOTICE CHARACTERISTICS SHOWN

VIA DIVISIONE JULIA, 7/B - 36031 DUEVILLE [VI] ITALY • TEL. 0039.0444.593290 - FAX. 0039.0444.593357 • E-MAIL. INFO@BINOTTO.COM

Edit.: 04 • 2006  
Rev.: 04 • 2007  
Date: 01.04.2006

Pag.: DVT\_7.002