

PRESA DI FORZA A COMANDO PNEUMATICO

PNEUMATIC CLUTCH POWER TAKE-OFF

CODICE PTO
PTO CODE

50-41

CAMBIO
GEARBOX

FULLER



DIAGRAMMA DI UTILIZZO WORKING CONDITION

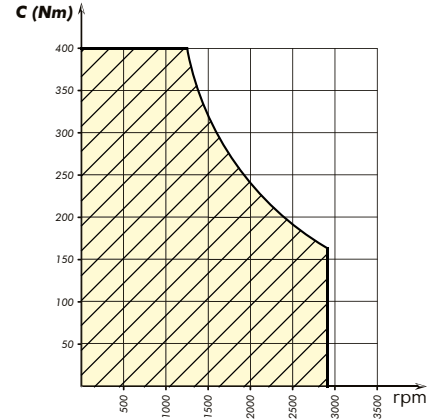

Interruttore segnalazione PTO inserita / PTO pressure signal switch

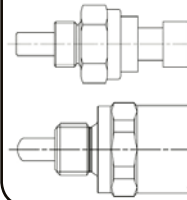

PACKARD
311-001-00116

DIN 72585
311-001-00205

OPTIONAL
Da ordinare separatamente
To be ordered separately

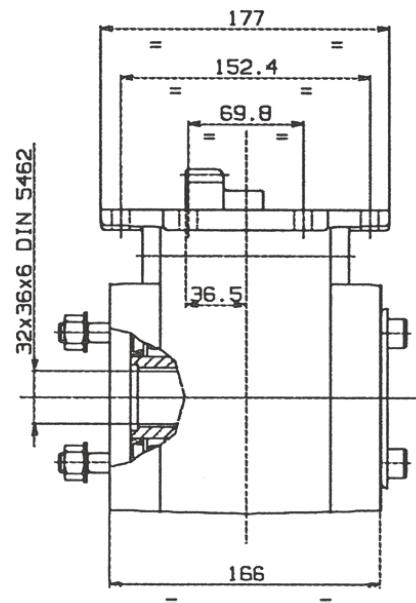
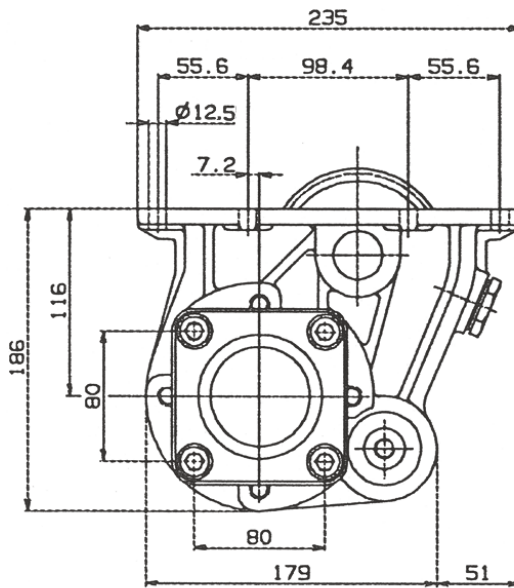

Tipo cambio Gearbox	Codice PTO PTO code	Versione Version	Giri pto a 1000 giri motore Pto ratio@1000 eng.rpm	Coppia massima Max torque	Lato montaggio Mounting side	Uscita Output	Rotazione Rotation	Kit di montaggio Mounting kit	Peso Weight
Vedi indice See index	50-41-176	17	Vedi indice See index rpm	400 Nm	Inf. Low side	Post. Rear	Ora. Cw	Vedi indice See index	20 Kg

pag.1

Binotto srl

Binotto®
THE TIPPING POWER

We reserve the right to make any changes without notice.
Edition 2014.07 No reproduction, however partial, is permitted.
Via Divisione Julia 7/B 36010 Dueville (Vicenza) Italy Tel.: +39 0444593290
Fax: +39 0444593357 Internet:www.binotto.com e-mail:info@binotto.com