

VALVES

TYPE : TIPPING VALVES

VLV.TYPE

DVT#

Pneumatic proportional tipping valve –Modular 150 Cartridge SL

Technical Characteristics



Valvola ad azionamento pneumatico per il comando di ribaltabili medio-pesanti, con schema idraulico a centro aperto in accordo alle direttive CE. Utilizzabile con il deviatore pneumatico tipo Kip-Air, per ottenere una modulazione continua della velocità di discesa.

- Valvola di ritegno e valvola di massima pressione registrabile (tipo differenziale) incorporate.
- Corpo in ghisa sferoidale per sopportare pressioni fino a 400 bar
- Possibilità di montaggio a telaio oppure flangiata direttamente al serbatoio (DSP).
- Fine-corsa meccanico ad azionamento diretto.
- Predisposizione per segnalatore di pressione.
- Corpo verniciato in cataforesi e cursore nichelato.
- Nella versione standard è garantito per lavorare con olio a temperature $-25 \div 80$ °C, campo di viscosità $12 \div 100$ cSt e grado di filtrazione $25 \mu\text{m}$.

Proportional pneumatic tipping valve to suit medium-heavy duty tipper trucks. Operated by proportional cab control. Open center hydraulic scheme according to CE standards.

- Built-in check and adjustable safety valves (differential cartridge type).
- Nodular cast-iron body for pressure up to 400 bar.
- Either Chassis or tank (DSP kit) mounting options.
- Mechanical Direct End-of-stroke with anti-shock spring.
- Ready for pressure signal switch mounting.
- Cataphoresis coated body and nickel spool.
- In the standard configuration guaranteed for oil temperature range $-25 \div 80$ °C, viscosity range $12 \div 100$ cSt and oil filtering $25 \mu\text{m}$.

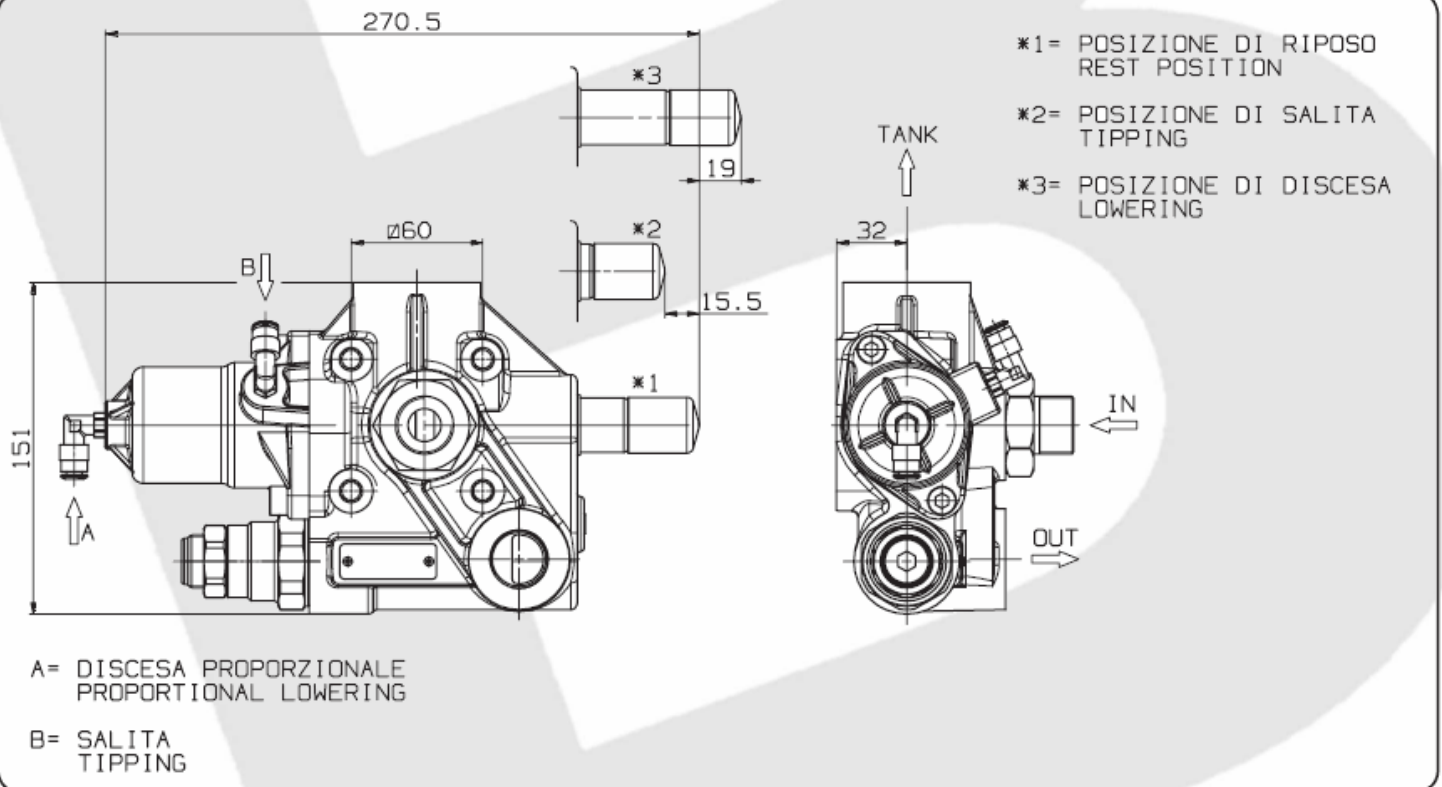

Tipo deviatore Tipping valve type	Codice ordinazione Order code	IN	TANK	OUT	Peso Weight Kg	Temp. °C
MODULAR 150 CE	DVT#T	ISO 228	ISO 228	ISO 228		-50°C
	DVT#U	G 3/4	G 1 1/4	G 3/4		

BINOTTO SRL

BINOTTO IS CONTANTLY ENGAGED IN IMPROVING ITS PRODUCTS AND THEREFORE RESERVES THE RIGHT TO MODIFY WITHOUT ANY NOTICE CHARACTERISTICS SHOWN

VIA DIVISIONE JULIA, 7/B - 36031 DUEVILLE (VI) ITALY • TEL. 0039.0444.593290 - FAX. 0039.0444.593357 • E-MAIL. INFO@BINOTTO.COM

Edit.: 04 • 2006
Rev.: 04 • 2007
Date: 01.04.2006

Pag.: DVT_T.001

VALVES

TYPE : TIPPING VALVES

VLV.TYPE

DVT#

Pneumatic proportional tipping valve –Modular 150 Cartridge SL

Technical Characteristics

Tipo deviatore Tipping valve type	Codice ordinazione Order code	Pressioni Pressure values		Portata Flow l/min
		Taratura standard Standard pressure setting bar	Taratura massima Max. pressure setting bar	
MODULAR 150 CE	DVT#T	160	350	150
	DVT#U			

Perdite di carico deviatore
Tipping valve pressure drops

Curva caratteristica p-Q valvola di massima
p-Q operating curve for pressure relief valves

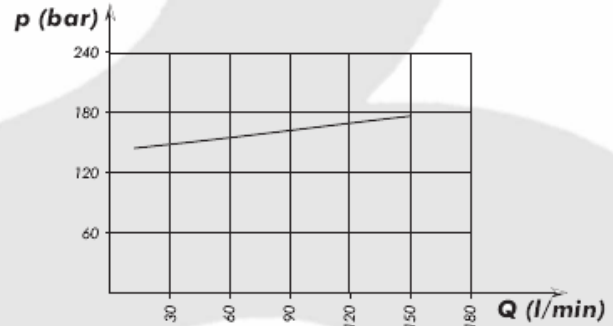
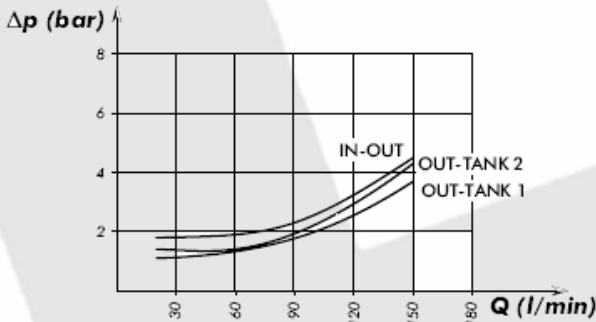

Rilievi eseguiti con olio ISO VG 46 a 50°
The graph refers to oil type ISO VG 46 a 50°

Schema di funzionamento
Functional diagram

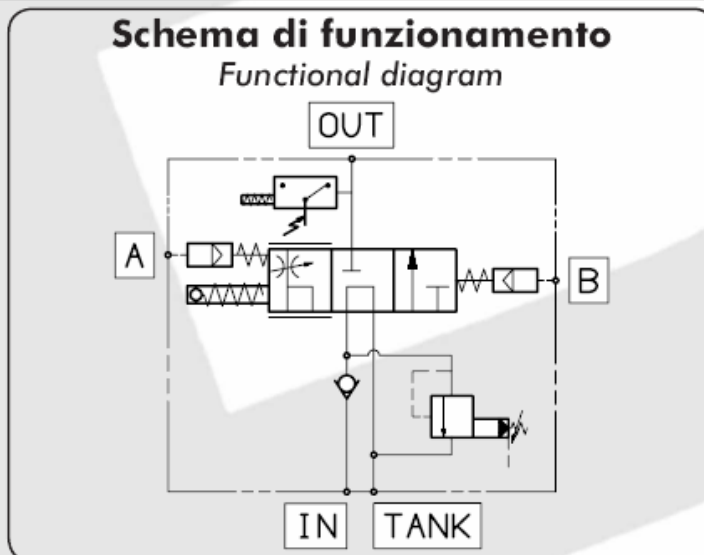

BINOTTO SRL

BINOTTO IS CONTANTLY ENGAGED IN IMPROVING ITS PRODUCTS AND THEREFORE RESERVES THE RIGHT TO MODIFY WITHOUT ANY NOTICE CHARACTERISTICS SHOWN

VIA DIVISIONE JULIA, 7/B - 36031 DUEVILLE [VI] ITALY • TEL. 0039.0444.593290 - FAX. 0039.0444.593357 • E-MAIL. INFO@BINOTTO.COM

Edit.: 04 • 2006

Rev.: 04 • 2007

Date: 01.04.2006

Pag.: DVT_T.002