

# PRESA DI FORZA A COMANDO ELETTROMAGNETICO ELECTROMAGNETIC CLUTCH POWER TAKE-OFF

**CODICE PTO**  
PTO CODE

**85-562**

**CAMBIO**  
GEARBOX

**GAZ-GAZEL**



## DIAGRAMMA DI UTILIZZO WORKING CONDITION

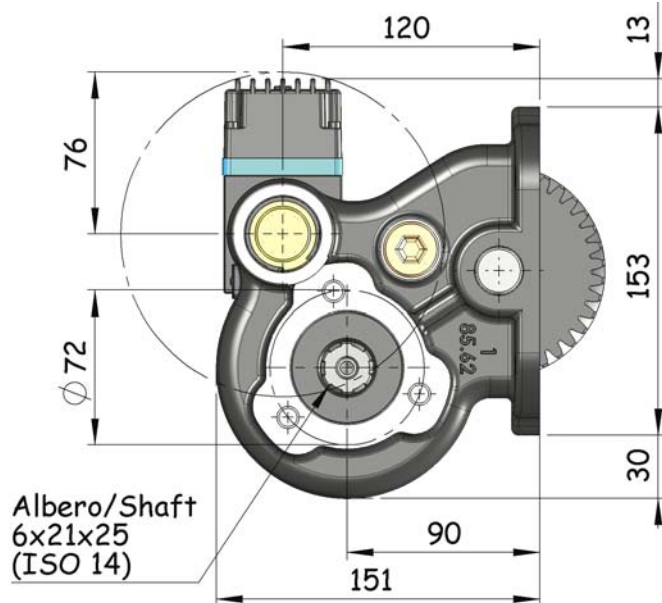
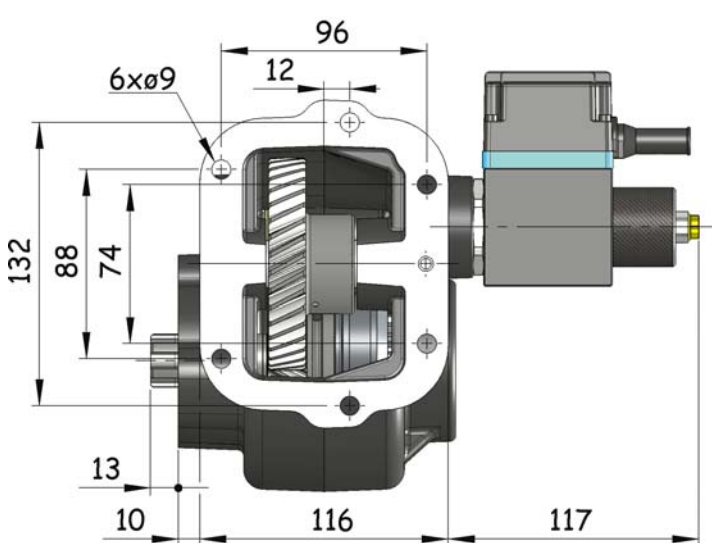
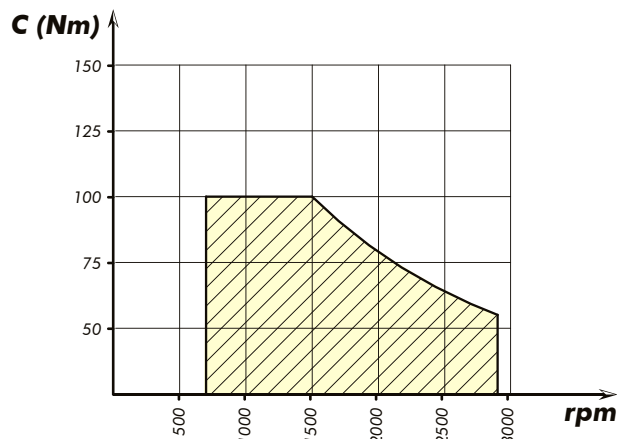

Tipo cambio Gearbox	Codice PTO PTO code	Versione Version	Giri pto a 1000 giri motore Pto ratio@1000 eng.rpm	Coppia massima Max torque	Lato montaggio Mounting side	Uscita Output	Rotazione Rotation	Kit di montaggio Mounting kit	Peso Weight
<b>GAZ 3302 33023</b>	<b>85-562-146</b>	14	rpm 767	Nm <b>100</b>	Dx Right	Anter. Front	Ant. Acw	154-3-2241	Kg 11,5

Codice foglio: 997-285-56214 Rev://

Rev://

Codice fascicolo://

Data: Giovedì 12 aprile 2007