

PRESA DI FORZA A COMANDO PNEUMATICO

PNEUMATIC CLUTCH POWER TAKE-OFF

CODICE PTO
PTO CODE

2-72

CAMBIO
GEARBOX

IVECO

Codice foglio: 997-202-07217 Rev://



DIAGRAMMA DI UTILIZZO WORKING CONDITION

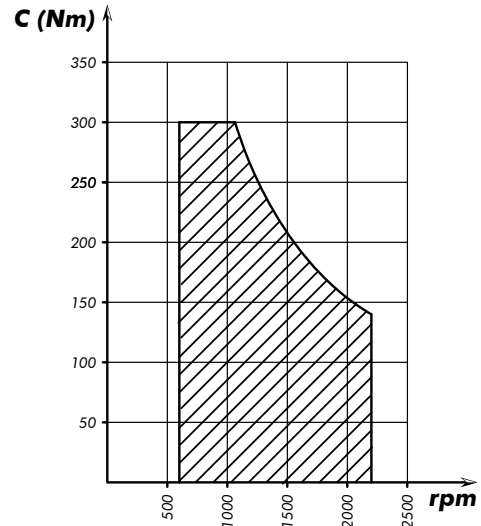

Rev://

Codice fascicolo:

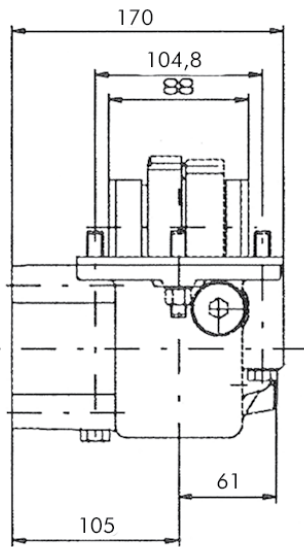

Mozzo/Hub
8x32x36
(ISO 14)

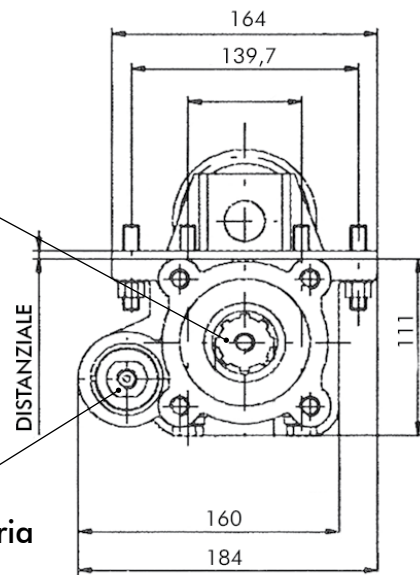

Attacco raccordo aria
Air inlet
G 1/8

Data: Venerdì 19 dicembre 2003

Tipo cambio Gearbox	Codice PTO PTO code	Versione Version	Giri pto a 1000 giri motore Pto ratio@1000 eng.rpm	Coppia massima Max torque	Lato montaggio Mounting side	Uscita Output	Rotazione Rotation	Kit di montaggio Mounting kit	Peso Weight
SPR 2845.6/6,33	2-72-170	17	rpm	Nm	Dx Right	Post. Rear	Ora. Cw	154-0-40	Kg
SPR 2855.5/6,33			776	300					
SPR 2855.6/6,33			1030						