

PRESA DI FORZA A COMANDO PNEUMATICO PNEUMATIC CLUTCH POWER TAKE-OFF

CODICE PTO
PTO CODE

086-3-2175

CAMBIO
GEARBOX

KAMAZ

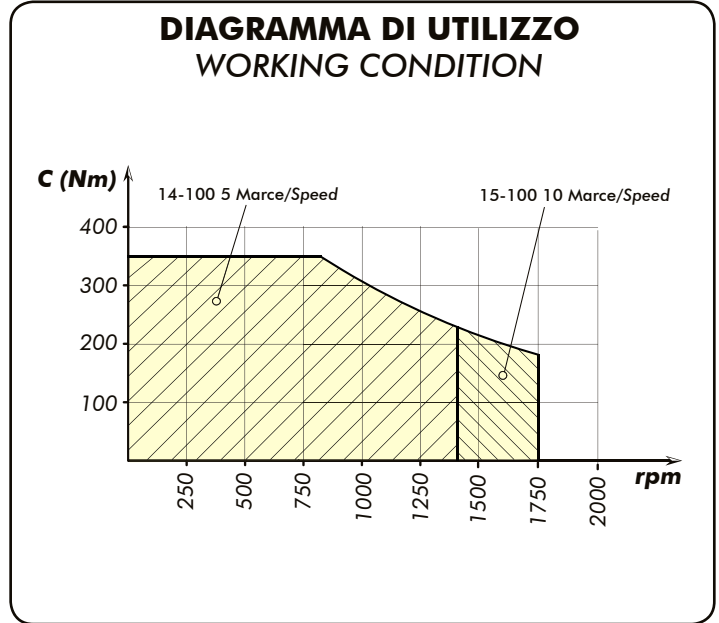

Interruttore segnalazione PTO inserita / PTO signal switch



PACKARD
311-001-00116



DIN 72585
311-001-00205

OPTIONAL
Da ordinare
separatamente
To be ordered
separately

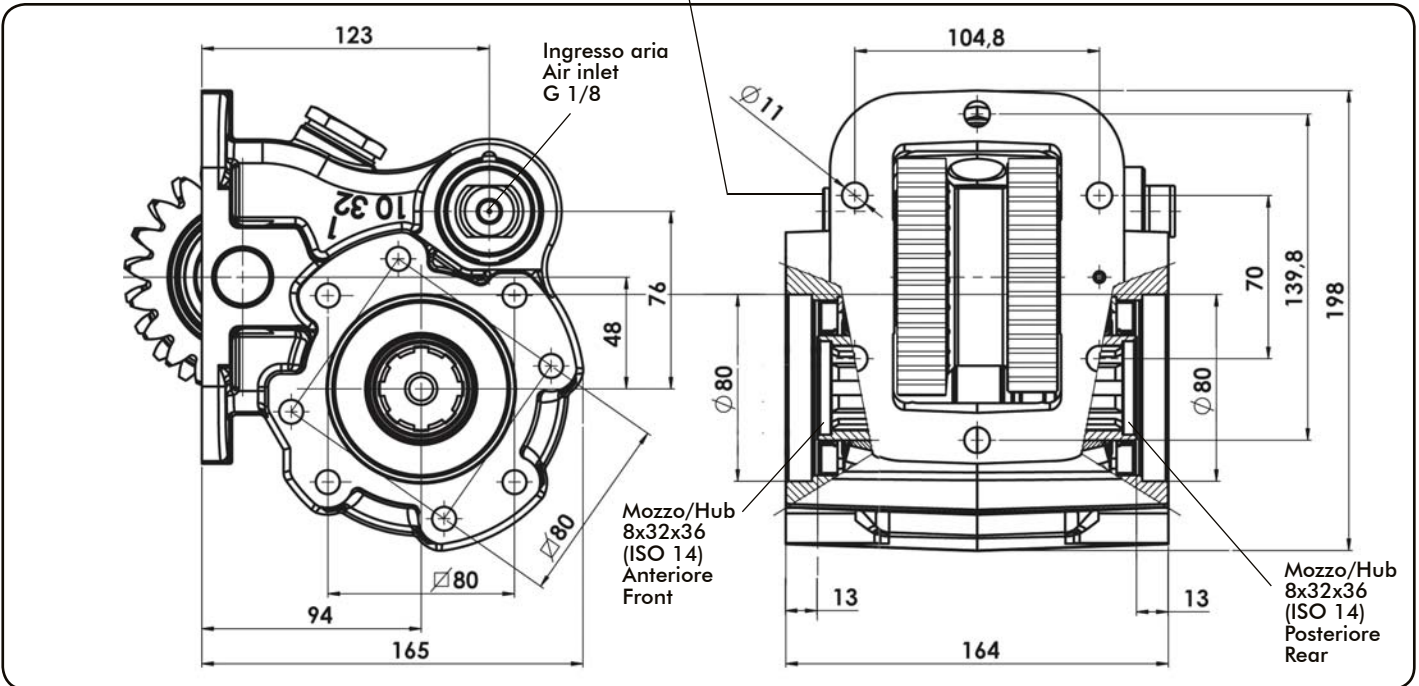

Tipo cambio Gearbox	Codice PTO PTO code	Versione Version	Giri pto a 1000 giri motore Pto ratio@1000 eng.rpm	Coppia massima Max torque Nm	Lato montaggio Mounting side	Uscita Output	Rotazione Rotation	Kit di montaggio Mounting kit	Peso Weight Kg		
KAMAZ 14-100 5 MARCE/SPEED	086-3-2175	217	Lenta Low	350	Dx Right	Post. Rear	Orario (Anteriore) Antiorario (Posteriore) Cw (Front) Acw (Rear)	154-3-3044	9.8 Kg		
			Veloce High							661	-----
KAMAZ 15-100 10 MARCE/SPEED			661							812	

Data: Martedì 15 ottobre 2013

Codice foglio: 997-286-03217 Rev: //