

PRESA DI FORZA A COMANDO PNEUMATICO

PNEUMATIC CLUTCH POWER TAKE-OFF

CODICE PTO
PTO CODE

28-23

CAMBIO
GEARBOX

SCANIA



DIAGRAMMA DI UTILIZZO WORKING CONDITION

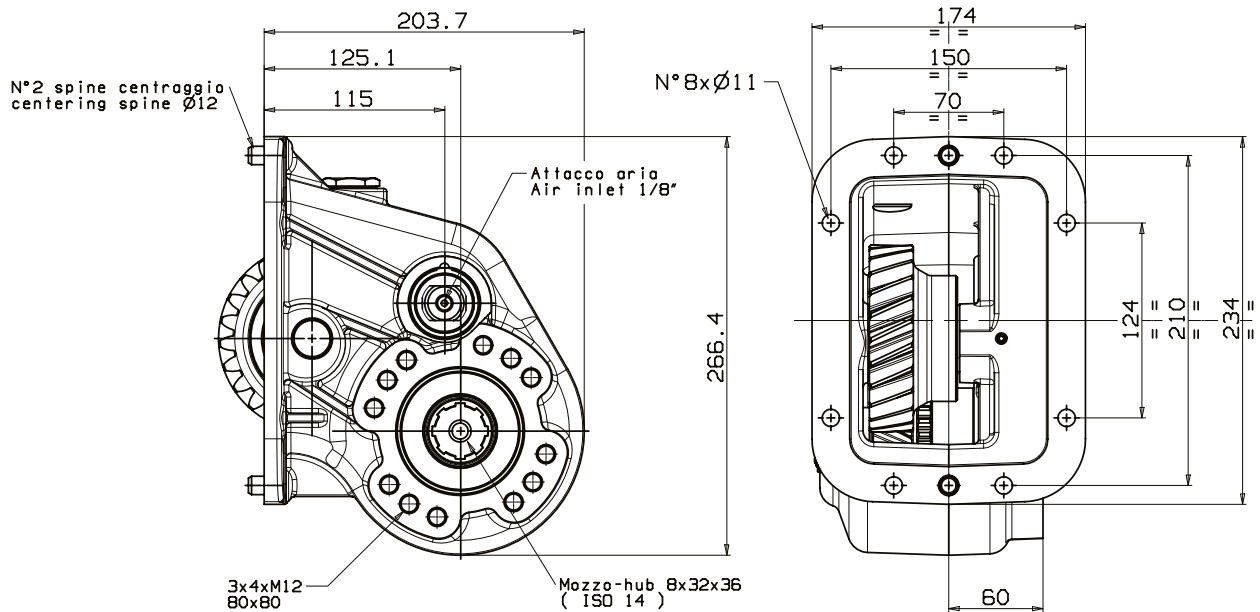
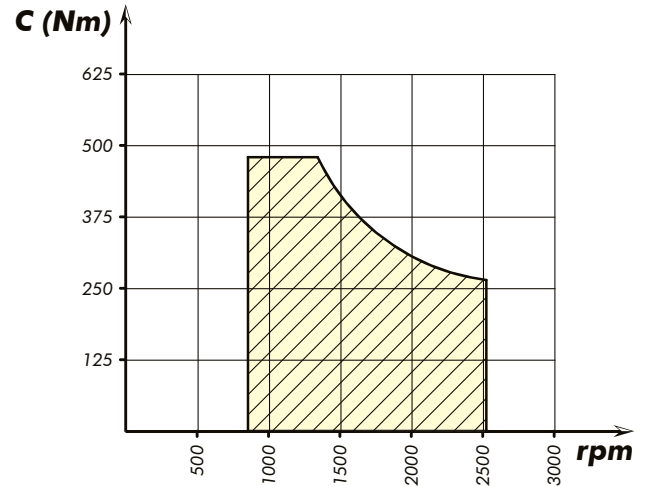

Tipo cambio Gearbox	Codice PTO PTO code	Versione Version	Giri pto a 1000 giri motore Pto ratio@1000 eng.rpm		Coppia massima Max torque	Lato montaggio Mounting side	Uscita Output	Rotazione Rotation	Kit di montaggio Mounting kit	Peso Weight
			NORM.	VEL.						
GRS 900 GRS 920	28-23-175	17	1260	1547	480	Dx Right	Poster. Rear	Ora. Cw	154-3-6041	18,3