

**Diagramma di utilizzo**  
*Working conditions*

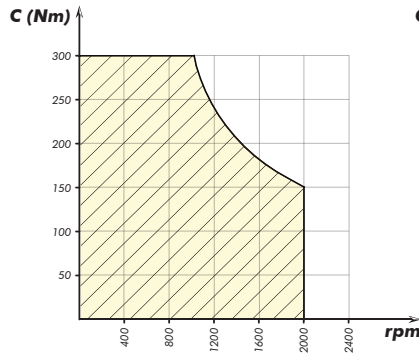

01602100172

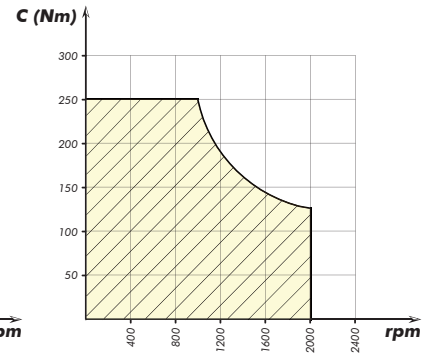

01602200171  
01602300170

**Ingombro / Dimensions**

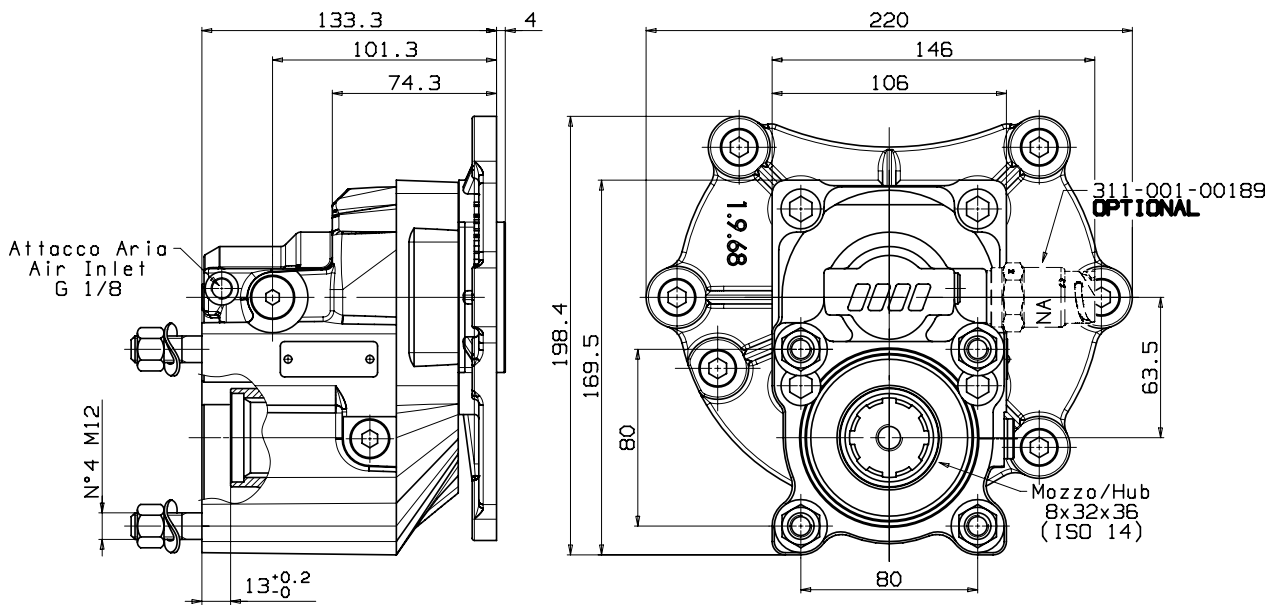

**Dati tecnici / Technical features**

Tipo cambio <i>Gearbox type</i>	Codice PTO <i>PTO code</i>	Rapporto interno <i>Internal ratio</i>	Versione <i>Version</i>	Giri pto a 1000 giri motore <i>Pto ratio@1000 eng.rpm</i>	Coppia massima <i>Max torque</i>	Uscita <i>Output</i>	Lato montaggio <i>Mounting side</i>	Rotazione <i>Rotation</i>	Kit montaggio <i>Mounting kit</i>	Peso <i>Weight</i>
					Nm					Kg
MERCEDES G60-6/9 G85-6/9	01602100172	1:1,81	17	815	300	Posteriore <i>Rear</i>	Posteriore <i>Rear</i>	Antioraria <i>Ccw</i>	15400303455	10,8
	01602200171	1:1,53		1123						
	01602300170	1:1,31		686	250					
		946								
		588								
				810						