

Вал отбора мощности для автоматической КПП ZF

ALBERO DI CORREDO
QUILL SHAFT
"ZF 12AS-1800...
16AS-2630 ..."

CODICE
CODE

093-006-00053

ZF



In fase di montaggio verificare che l'anello posizione 5 sia interno di 0,2-0,5 mm rispetto al Piano del cambio.

In assembly phase check that the position 5 ring is internal by 0.2-0.5 mm, with respect to the trasmission surface.

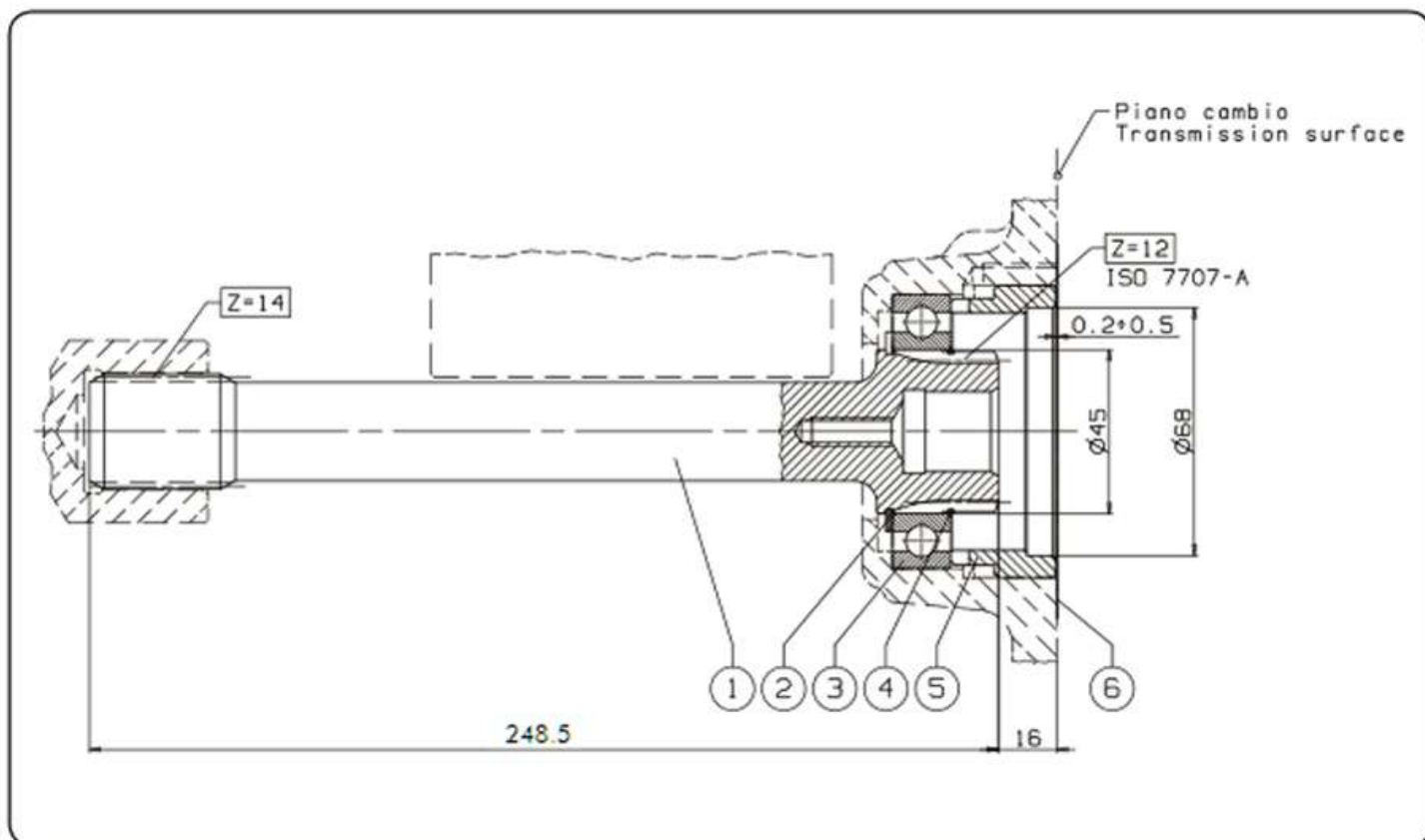

N°	Codice Code	Descrizione Description	Q.
1	521-000-00989	Albero di corredo / Quill shaft	1
2	501-002-00425	Anello seeger / Circlip E 45	1
3	510-001-45755	Cuscinetto a sfere / Ball bearing 45x75x16	1
4	512-000-00068	Anello ferma cuscinetto / Bearing back-up ring	1
5	534-002-00079	Anello centraggio - guida PTO / Centering ring - PTO guide	1
6	507-001-00077	Guarnizione / Gasket	1